



Operating Instructions

WHEELCHAIR ACCESS VEHICLE WITH REAR CUT-OUT

OPEL VIVARO / RENAULT TRAFIC / FIAT TALENTO WITH AMF-BRUNS EASY- AND EASY-FLEX-RAMP



www.amf-bruns.de

Foreword

Dear reader,

these Operating Instructions provide all information necessary to operate the Easy and Easy-Flex wheelchair access ramps safely.

The access ramp is designed and constructed in accordance with state of the art technology and recognised safety standards. Persons and material assets can however still be at risk, because not all danger areas can be eliminated if the functional capability is to be maintained. Accidents caused by these dangers can however be prevented by strictly observing these Operating Instructions. Over and above this, the operational efficiency of the access ramp can be used to the full and unnecessary faults can be prevented.

After reading these Operating Instructions for the first time, keep them in a safe place for future reference over the entire lifetime of the vehicle. If you sell the vehicle, hand these Operating Instructions over to the new owner.

All details, figures and dimensions contained in these Operating Instructions are non-binding. They cannot be used as the basis for any claims whatsoever.

This document must not be reproduced or duplicated, in full or in part, without the prior, written permission of the manufacturer.

The access ramp must never be converted or modified in any way, without seeking the prior, written permission of the manufacturer. Unauthorised modifications will render the manufacturer's liability and guarantee null and void.

Use only original spare parts or spare parts which have been approved of by the manufacturer. If spare parts other than these are used, this can have a negative effect on the specified characteristics, the functionality and safety of the access ramp. The use of any other parts will therefore render the liability for resultant damage null and void.

Contact our customer services department to order spare parts or accessories (see Chapter 10, page 51).

Explanation of symbols and signs

To improve understanding, the following conventions should be met for these Operating Instructions:

1.

The following conventions are used to highlight important information:



DANGER!

- warns of a situation of immediate danger, which will lead to severe or fatal injuries, if not avoided.



WARNING!

- warns of a potentially dangerous situation, which will lead to severe or fatal injuries, if not avoided.



CAUTION!

- warns of a potentially dangerous situation, which will lead to slight or minor injuries or material damage if not avoided.



ATTENTION!

...indicates a potentially dangerous situation, which can cause material damage, if not avoided.



...contains general notes and useful information.



...indicates important information contained in other sections and documents.

2.

Some text passages serve a special purpose. These are highlighted as follows:

- Lists.

⇒ Instructional text, e.g. a series of activities.

3.

Meaning of directions:

If directions are given in the text (in front of, front, behind, rear, right, left), these directions relate to the normal direction of travel of the vehicle.

Contents

| | |
|--|-----------|
| Foreword..... | 3 |
| Contents..... | 6 |
| 1 Safety | 8 |
| 1.1 Proper Use..... | 8 |
| 1.2 Improper Use | 9 |
| 1.3 Personnel Requirements..... | 10 |
| 1.4 Product Monitoring | 10 |
| 1.5 Danger Zone | 11 |
| 1.6 Safety Devices | 11 |
| 1.7 Safety and Accident Prevention Regulations | 12 |
| 1.8 Decommissioning and Conservation | 13 |
| 1.9 Disposal | 13 |
| 2 Description | 14 |
| 2.1 Layout and Function..... | 14 |
| 2.1.1 Floor section..... | 15 |
| 2.1.2 Ramp..... | 15 |
| 2.1.3 Belts and belt anchorages..... | 16 |
| 2.2 Rating Plate | 17 |
| 2.3 Operating Controls..... | 18 |
| 2.4 Technical Data | 19 |
| 3 Transportation..... | 19 |
| 4 Installation / Commissioning | 19 |
| 5 Operation..... | 20 |
| 5.1 Safety Regulations for Operation..... | 20 |
| 5.2 Deploying the Ramp..... | 22 |
| 5.3 Folding or Removing | |
| a Third Row of Seats (optional) | 24 |
| 5.4 Loading a Passenger / Wheelchair..... | 26 |
| 5.5 Disembarking a Passenger / Unloading | |
| a Wheelchair | 29 |
| 5.6 Easy-Flex: Fully Stowing the Ramp..... | 31 |

| | |
|---|-----------|
| 6 Maintenance and Repair | 33 |
| 6.1 Safety Regulations for Maintenance and Repair | 33 |
| 6.2 Routine Maintenance Work | 34 |
| 6.2.1 Maintenance schedule | 34 |
| 6.2.2 Maintenance records | 34 |
| 6.3 Functionally Testing the Electrically Operated Belts | 35 |
| 6.4 Yearly Inspection..... | 36 |
| 6.5 Maintenance and Repair Record..... | 36 |
| 7 Faults and Troubleshooting | 37 |
| 7.1 Troubleshooting Table..... | 37 |
| 7.2 Adjusting the Access Ramp’s Play | 38 |
| 8 Inspection Log..... | 39 |
| 8.1 Inspection Log Master Data Sheet | 40 |
| 8.2 Inspection List..... | 41 |
| 8.3 Inspection Results..... | 42 |
| 9 Electrical Circuit Diagram | 50 |
| 10Customer Service | 51 |

1 Safety



CAUTION!

There are a number of risks of suffering personal injury and material damage involved in the operation and maintenance of the access ramp.

Therefore:

- it is imperative, that these Operating Instructions are read thoroughly before operating your access ramp. Always follow the instructions and information therein, particularly the safety instructions.
 - If these Operating Instructions or parts thereof are lost or become illegible, please request a new copy from the manufacturer.
-

Prerequisite to the safe handling and trouble-free operation of the access ramp is a thorough knowledge of the applicable safety information and the safety regulations.

It is therefore imperative that this Chapter is read thoroughly before operating the access ramp and that the instructions and warnings herein are strictly observed. The safety information and warnings, given at the appropriate places in the following Chapters, must also be strictly observed. The manufacturer will not be held responsible if safety information and warnings are not adhered to.

In addition to the information given in these Operating Instructions, local legislative regulations must be taken into consideration, in particular those regarding safety and accident prevention.

1.1 Proper Use

The access ramp must only be used for transporting a disabled person in a wheelchair or an empty wheelchair. By using the access ramp, persons can be loaded into or disembarked from the vehicle to which it is fitted. When doing so, the access ramp will be operated by an accompanying person.

Wheelchairs must be equipped with the fittings necessary to secure it by means of the belt restraint systems provided.

Proper use also includes strictly adhering to the information given in these Operating Instructions.



WARNING!

If the access ramp is used for any other purpose than that described above, this may result in dangerous situations for persons or material damage being caused.

Therefore:

- only use the access ramp for the purpose for which it was intended.
- Always adhere to information given in these Operating Instructions.
- Do not use the access ramp for any other use, particularly those given in Section 1.2. These are deemed to be improper use.

1.2 Improper Use

Any use other than that described in Section 1.1 is deemed to be improper use.

The access ramp is deemed to be improperly used if for example:

- it is used to transport goods,
- it is used in a faulty state or with safety-relevant malfunctions,
- it is used to transport wheelchairs that can not be secured by means of the belt restraint systems provided, or
- it is used by incompetent persons.

1.3 Personnel Requirements

The access ramp must only be handled by persons who:

- have been instructed in how to operate the access ramp,
- have read and understood these Operating Instructions,
- have proven their ability to operate the access ramp to the vehicle's owner,
- have been expressly assigned by the vehicle's owner to operate the access ramp,
- have the technical knowledge to operate the wheelchair's brakes and switch the motors of electrically driven wheelchairs ON and OFF and
- are in a position to adapt themselves to the particular behaviour and needs of disabled persons.

Transportation, installation, commissioning, maintenance, repair, fault finding and disposal of the access ramp and the vehicle itself must only be carried out by persons with the corresponding technical training and experience.

1.4 Product Monitoring

Please contact AMF-Brunns GmbH & Co. KG immediately if faults or problems are encountered when operating your access ramp or if accidents or "near-misses" occur.

AMF-Brunns will effect a solution to the problem with your help and the knowledge gained will flow into future projects.

NOTE



Guarantee work on the access ramp must only be carried out with the prior agreement of AMF-Brunns GmbH & Co. KG.

The costs of such work will not be accepted by AMF-Brunns without prior agreement.

1.5 Danger Zone

The danger zone is the area behind the access ramp that is being deployed, in which a person can be injured through the movement of the access ramp.

CAUTION!

Risk of injury and danger of material damage when deploying the access ramp.

There is a risk of injuries to the legs and feet if the access ramp is allowed to fall to the ground out of control. The access ramp can be damaged.

Therefore:

- Keep hold of the access ramp until it is fully in contact with the ground.
 - Allow the access ramp to deploy slowly.
-



1.6 Safety Devices

Electrically operated belts

Electrically operated belts, with which the wheelchair is secured when driving, are attached to the front area of the vehicle's floor. These electrically operated belts can only be pulled out when the ramp has been fully deployed and the indicator lamp in the rocker switch is lit (refer to Section 2.3, page 18). The electrically operated belts retract automatically when the rocker switch is in either position. Before the wheelchair can be pushed or driven up the ramp, the electrically operated belts must be attached to the wheelchair and the rocker switch must be operated such that the indicator lamp goes out. This will prevent the wheelchair from rolling back out of control.

1.7 Safety and Accident Prevention Regulations

Adhere to the following notes in order to prevent personal injuries and material damage. For commercial use, also adhere also to the relevant safety and accident prevention regulations laid down by the trade associations.

- The access ramp must only be operated if all safety devices are correctly fitted (see Section 1.6, page 11). These devices must only be removed for maintenance and repair work. All safety devices must be replaced immediately after such work has been completed. Otherwise, there is a high risk of injury.
- The access ramp must only be used for the purpose for which it is intended, otherwise dangerous situations, with resultant injuries, may occur (Proper use: see Section 1.1, page 8).
- The owner is responsible for ensuring that proper use is adhered to, in particular that the access ramp is only operated by authorised persons.
- If the access ramp is used commercially or as a public utility, the owner must ensure that operating personnel are familiar with the operation of the access ramp under all operating conditions by giving training and familiarisation courses.
- Proper use of the access ramp also includes adherence to the specified maintenance and repair work, in particular strict adherence to the maintenance intervals. If such work is not carried out, trouble-free operation can not be guaranteed. There is a risk of personal injury and material damage being caused. We recommend that maintenance records are kept.
- If the access ramp is used commercially or as a public utility, it must be inspected by a technical expert at intervals of not more than 1 year after commissioning. During inspection, faults affecting the safety should be systematically identified and remedial action taken (see "Inspection Log", page 39).

- The access ramp must not be operated in a faulty condition, as severe injuries can be caused by this. If faults occur, do not use the access ramp until repairs have been effected.
- Before carrying out maintenance or repair work, this includes cleaning work, switch the vehicle's engine OFF and prevent the vehicle from rolling away by applying the handbrake. Make certain that no other person can start the vehicle (e.g. by removing the ignition key). Otherwise, there is a risk of injury.
- Use only original spare parts and accessories or those approved of by the manufacturer. If other parts are used, the manufacturer will not accept liability for the consequences.

1.8 Decommissioning and Conservation

For queries regarding de-commissioning and conservation, contact our customer services department (see Chapter 10, page 51).

1.9 Disposal

When the access ramp and vehicle's useful life has expired, they must only be disposed of by qualified specialists. The manufacturer will accept no liability for damage caused by incorrect disposal.

2 Description

Persons who are wheelchair-bound can be loaded into or disembarked from a vehicle via the access ramp.

The main components of the access ramp are:

- the floor section,
- the ramp,
- the electrically operated belts and retractors for securing the wheelchair.

The aim of this chapter is to illustrate the construction and function of the access ramp. For this purpose, the individual assemblies and components are described in the Sections that follow.

2.1 Layout and Function



Ramp

Floor section

Figure 1: Ramp in the Deployed Position

2.1.1 Floor section

The floor section (see Figure 1, page 14) offers sufficient space for the passenger in the wheelchair. The surface of the floor section is lower than the floor of the vehicle. This ensures that the passenger has sufficient headroom.

2.1.2 Ramp

The Easy-Ramp is used in two positions.

In the completely deployed position, the ramp provides a slope, via which the wheelchair can be easily pushed or driven into the vehicle (see Figure 1, page 14).

The rear doors can be closed when the access ramp is in the vertical position. The ramp leaves sufficient space for a passenger or an empty wheelchair. In this position, the frame of the access ramp fills the gap in the vehicle's rear bumper (see Figure 2).

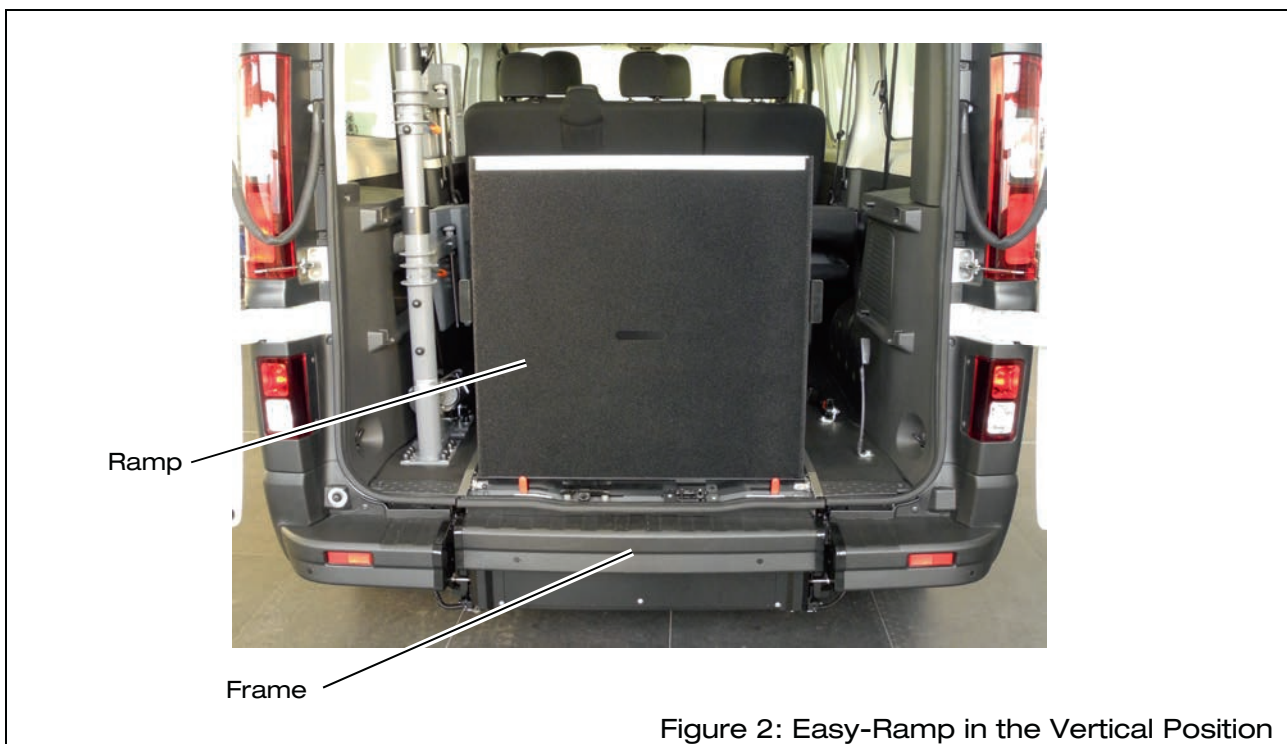

Figure 2: Easy-Ramp in the Vertical Position

A third position is available for the Easy-Flex-Ramp. The ramp can be folded down into the vehicle, so that it is at the same level as the floor of the vehicle (see Figure 3, page 16).

Description

The floor section is almost completely covered. This creates a level luggage compartment floor. The vehicle can be used without difficulty to transport goods and other items, up to a weight of 100 kg, in the normal way.

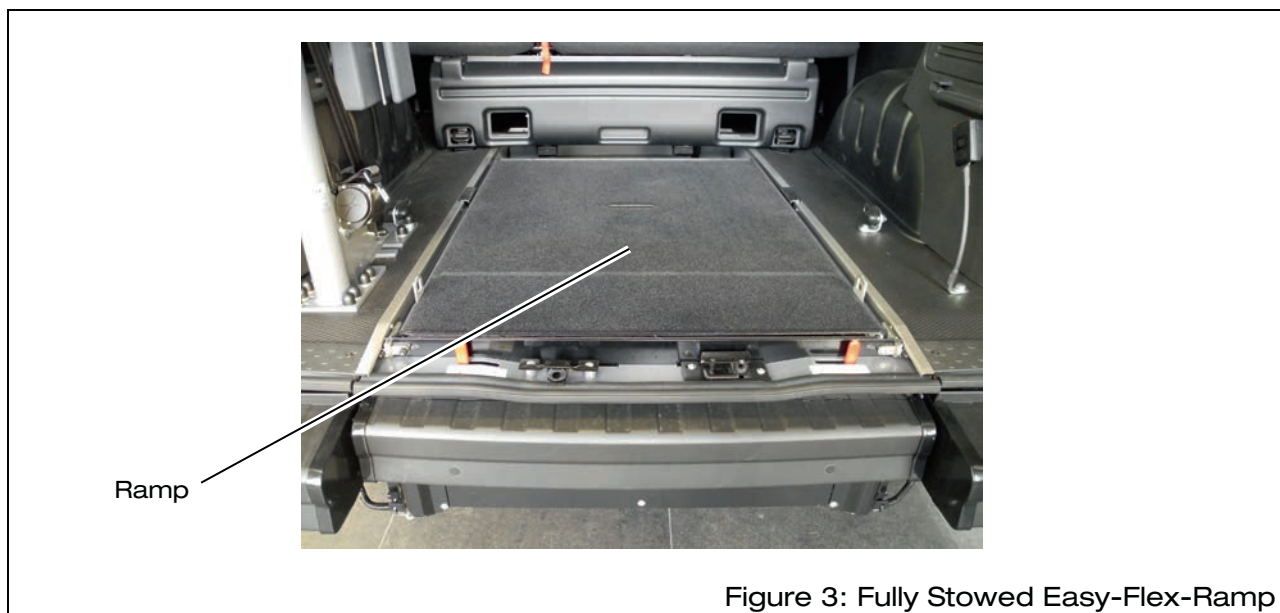

Figure 3: Fully Stowed Easy-Flex-Ramp

2.1.3 Belts and belt anchorages

Two electrically operated belts, for securing a wheelchair, are fitted to the front area of the floor section (see Figure 4). The electrically operated belts can be pulled out when the ramp is fully deployed and the indicator lamp in the rocker switch is lit.

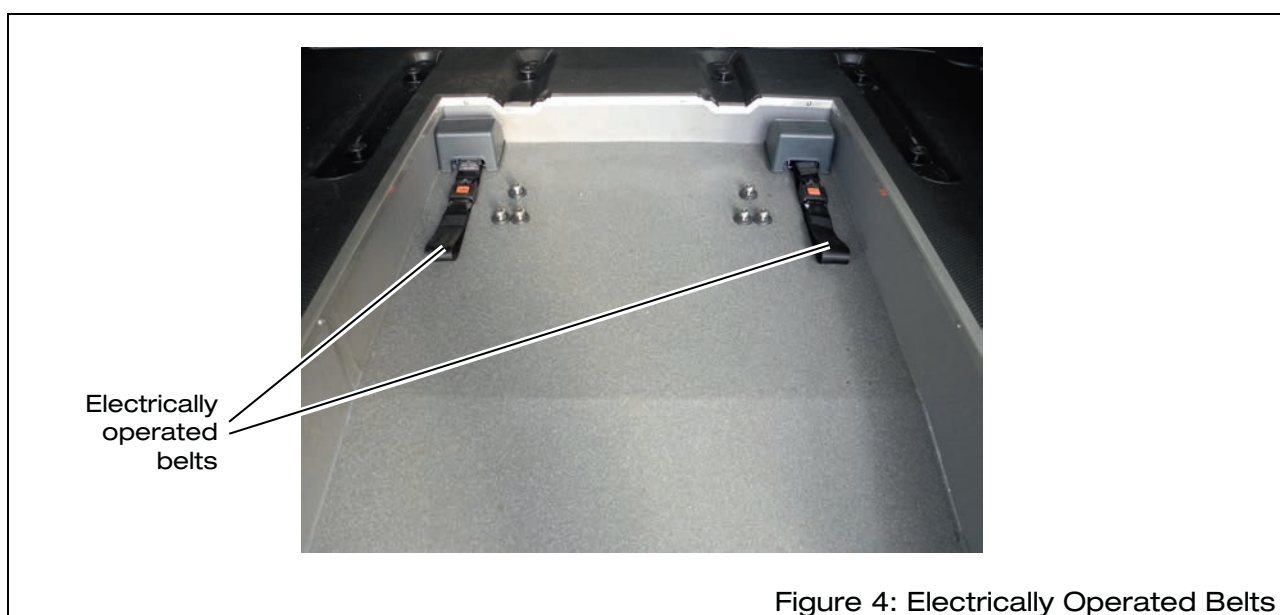
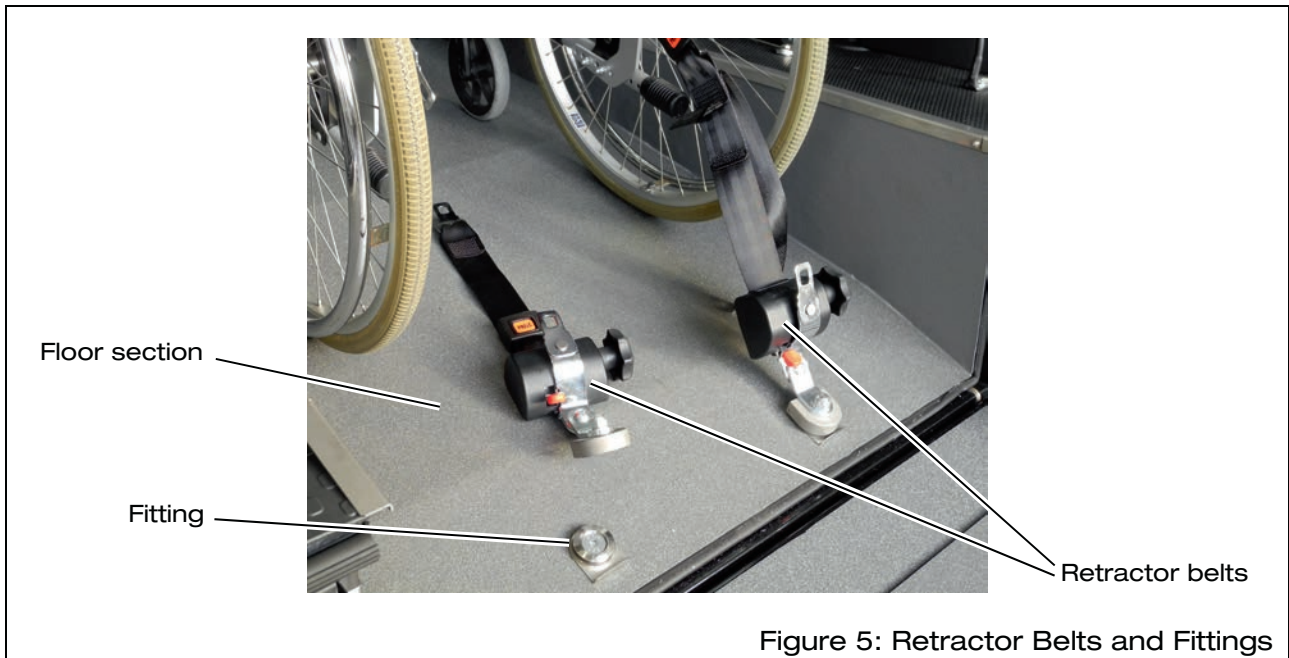

Figure 4: Electrically Operated Belts

Fittings, to which the retractor belts can be attached, are provided on the rear area of the floor section (see Figure 5). The rear end of the wheelchair is secured by the retractor belts.



2.2 Rating Plate

A rating plate, which contains the fundamental data, is attached to the access ramp (see Figure 6).

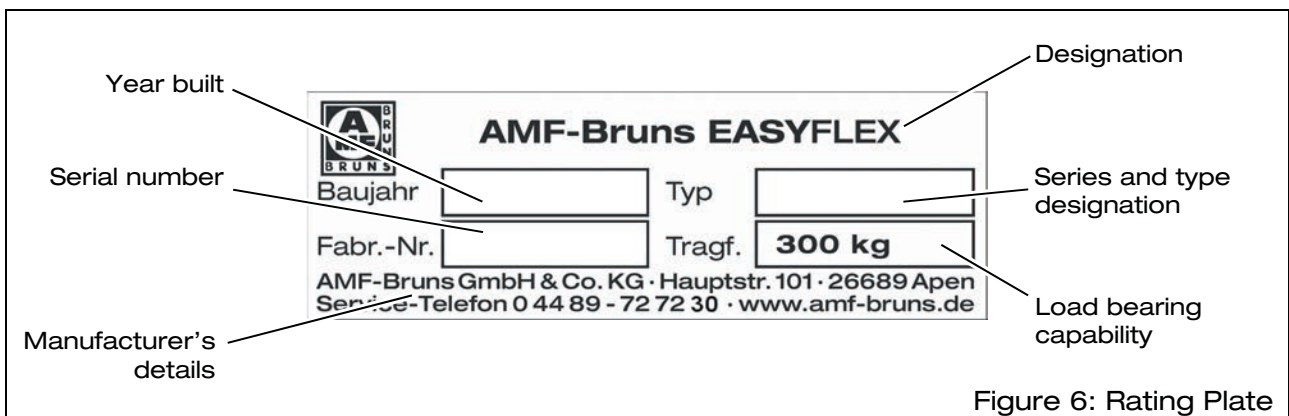

2.3 Operating Controls

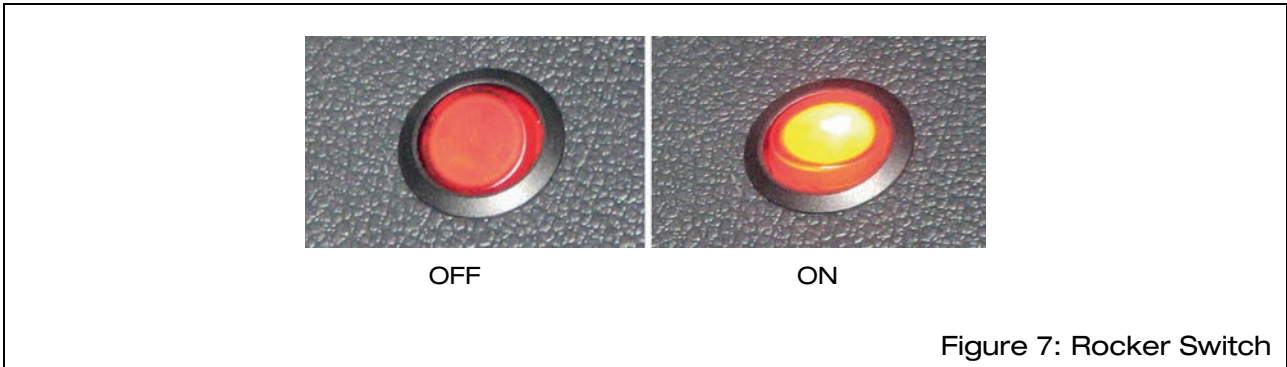

Figure 7: Rocker Switch

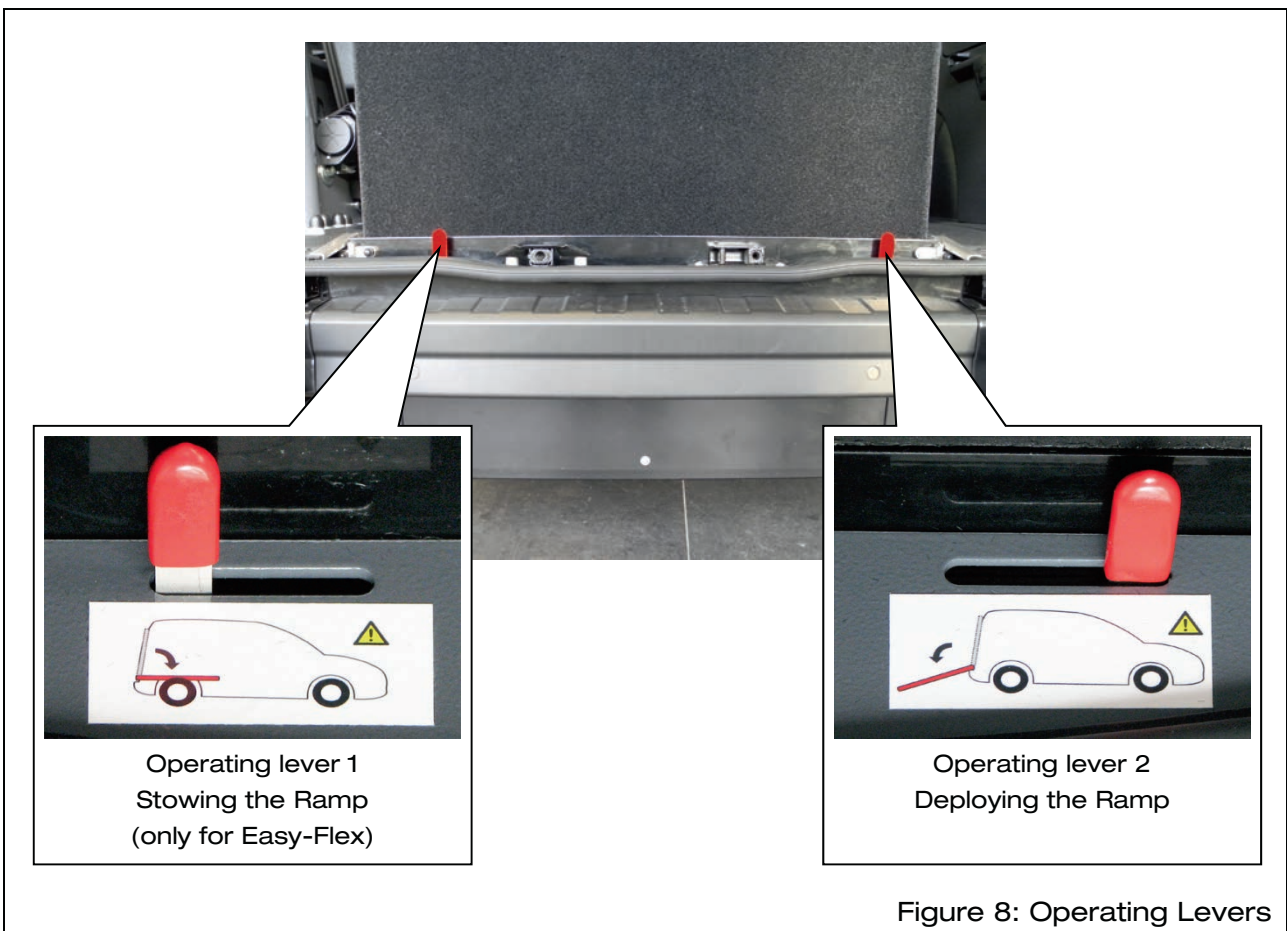

Figure 8: Operating Levers

| Designation | Function |
|--|--|
| Rocker Switch | Allows the electrically operated belts to be pulled out. |
| Operating lever 1 (only for Easy-Flex) | Allows the ramp to be folded down inside the vehicle to the horizontal position. |
| Operating lever 2 | Allows the ramp to be deployed. |

2.4 Technical Data

| | |
|--|-----------------------------|
| Designation | Easy-Ramp Easy-Flex-Ramp |
| Maximum load (wheelchair use) | 300 kg |
| Maximum load (Easy-Flex-Ramp stowed position, luggage compartment) | 100 kg |

3 Transportation

Transportation of the access ramp prior to installation is carried out by the manufacturer or by trained, experienced personnel.

4 Installation / Commissioning



The access ramp must be installed in accordance with the AMF-Bruns Installation Instructions applicable to the vehicle in question.

DANGER!

Risk of injury through incorrect installation.

A number of risks of personal injury and material damage can be caused if the access ramp is incorrectly installed in the vehicle.

Such risks can not only occur during installation but also as a result of installation not being carried out correctly.

Therefore:

- The access ramp must only be installed by specialist personnel, who have been trained for this job by the manufacturer. This also applies to the electrical connections.
- The vehicle manufacturer's body fitting guidelines must be adhered to.
- A technical expert must be called in to inspect the access ramp for correct installation and the effectiveness of the safety devices.
- The technical expert must confirm the fact that operational safety of the access ramp has been established by making a corresponding entry in the inspection log book (see Chapter 8, page 39).
- The access ramp must not be used until this has been done.



5 Operation

5.1 Safety Regulations for Operation



The safety information must have been read before operation (see Chapter 1, page 8).



WARNING!

Risk of injury and material damage if the access ramp is operated in a faulty condition.

Therefore:

- Always carry out inspections in accordance with the maintenance schedule before use (see Chapter 6, page 33).
- For communal or commercial use: Have the access ramp inspected at intervals of not more than one year by a technical expert.



WARNING!

Risk of injury and material damage if the access ramp is operated by unauthorised persons.

Dangerous operating conditions may be caused if the access ramp is operated by unauthorised persons.

Therefore:

- The access ramp must only be operated by persons who are familiar with operating the access ramp.
- The access ramp must never be operated by the passenger.
- Lock the vehicle's doors when the access ramp is not in use.



WARNING!

Risk of injury if safety devices are removed or are defective.

If safety devices are modified, bypassed or removed, they will no longer fulfil their function.

Therefore:

- Never modify, bypass or remove safety devices.
- Always refit safety devices if they have been removed (e. g. for maintenance or repair purposes).

WARNING!

Danger through road traffic collisions.

A number of risks are involved for the passenger operator when using the access ramp on public highways.

Therefore:

- When the parking the vehicle ensure that other road traffic is affected as little as possible.
- Park the vehicle such that as little danger as possible is presented to passenger and operator by other road traffic.
- Switch the vehicle's engine OFF and apply the handbrake before operating the access ramp.



CAUTION!

Risk of injury if there is insufficient space to operate the access ramp.

If there is insufficient space to leave or to get onto the access ramp, there is a risk of being injured by the access ramp or other objects (e. g. walls, posts or poles).

These risks apply to both passenger and accompanying person.

Therefore:

- When parking the vehicle, make certain that there is sufficient space behind the access ramp.



CAUTION!

Risk of personal injury and material damage.

The rear parking distance control warning characteristic is changed by fitting the ramp. The parking distance control first warns at a shorter distance from obstacles than usual.

Therefore:

- Bear the change in warning characteristic in mind when reversing.



5.2 Deploying the Ramp

- ⇒ Switch the vehicle's engine OFF.
- ⇒ Remove the ignition key.
- ⇒ Apply the vehicle's handbrake.
- ⇒ Open the rear doors.
- ⇒ For the Easy-Flex-Ramp: Use the handhold to fold the ramp back up to the vertical position, until it audibly engages (see Figure 9).

CAUTION!

Risk of crushing when lifting the ramp to the vertical position. When lifting the ramp to the vertical position, there is a risk of being crushed between the ramp and the frame (rear bumper).

Therefore:

- Do not reach into the gap between ramp and frame.



Figure 9: Folding the Ramp to the Vertical Position (only Easy-Flex)

- ⇒ Check that the ramp is securely engaged in the vertical position by gently shaking it.
- ⇒ Keep a firm hold on the ramp.
- ⇒ Push operating lever 2 to the left (see Figure 10, page 23).



Figure 10: Unlocking the Frame

⇒ Fold the ramp out until it makes contact with the ground (see Figure 11, page 24).

CAUTION!

Risk of injury and danger of material damage when deploying the ramp.

There is a risk of injuries to the legs and feet if the ramp is allowed to fall to the ground out of control. The ramp can be damaged.

Therefore:

- Keep a firm hold of the ramp until it is fully in contact with the ground.
- Allow the ramp to deploy slowly.





Figure 11: Deploying the Ramp

5.3 Folding or Removing a Third Row of Seats (optional)



NOTE

Long wheelbase vehicles have a third row of seats. These must be folded up or removed before loading a passenger or wheelchair into the vehicle. The seat retainers here must be removed.

- ⇒ Fold the third row of seats up (refer to the vehicle's Operating Instructions and Figure 12, page 25).
- ⇒ If necessary, remove the third row of seats (refer to the vehicle's Operating Instructions and Figure 14, page 26).
- ⇒ Lift the securing clip on a seat retainer in the floor section (see Figure 13, page 25).
- ⇒ Pull the seat retainer towards the rear.
- ⇒ Remove the seat retainer.
- ⇒ Repeat the procedure for the second seat retainer.



WARNING!

Danger of injury through the seat retainers.

If seat retainers are left lying loosely around, they can cause serious injuries if an accident occurs.

Therefore:

- Stow the seat retainers in a safe place (e. g. in the glove compartment).



Third row of seats

Figure 12: Third Row of Seats, Folded Up



Figure 13: Removing the Seat Retainers



Figure 14: Third Row of Seats and seat Retainers Removed

5.4 Loading a Passenger / Wheelchair

- ⇒ Accompany the wheelchair to a position in front of the deployed ramp.
- ⇒ Operate the rocker switch such that the indicator lamp in the rocker switch lights up (see Figure 7, page 18).
- ⇒ Pull the electrically operated belts out to the wheelchair.
- ⇒ Attach the electrically operated belts to the wheelchair (see Figure 15).



Figure 15: Attaching the Electrically Operated Belts to the Wheelchair

- ⇒ Operate the rocker switch such that the indicator lamp in the rocker switch goes out.



WARNING!

Risk of injury through the wheelchair rolling backwards.

The floor section and the ramp form a slope via which the wheelchair can roll back out of control. The passenger in the wheelchair can be severely injured. Material damage can be caused.

Therefore:

- Attach the electrically operated belts to the wheelchair.
- Operate the rocker switch such that the indicator lamp in the rocker switch goes out.
- Push or drive the wheelchair up the access ramp only when this has been done.

⇒ Push or drive the wheelchair into the vehicle.



WARNING!

Risk of injury if the electrically operated belts loosen when driving.

If the electrically operated belts are unevenly tensioned, they can become loose when driving. There is a risk of the passenger in the wheelchair and of the other occupants in the vehicle being injured

Therefore:

- Push the wheelchair into the centre of the vehicle.
- Make sure that the electrically operated belts leave the belt reels at the same angle as one another.
- If this is not the case, re-position the wheelchair.

⇒ Switch the motor of an electrically-driven wheelchair OFF.

⇒ Attach the retractor belts to the wheelchair.

⇒ Clip the retractor belts onto the fittings in the rear area of the floor of the vehicle (see Figure 16, page 28).

⇒ Tension the retractor belts by tightening the belt reels.



Retractor belt

Figure 16: Tensioning the Retractor Belts

- ⇒ Apply the wheelchair's brake(s).
- ⇒ Secure the passenger in the wheelchair with the lap belt, the automatic diagonal shoulder belt and the head and back support FutureSafe (optional).
- ⇒ Fold the ramp back up to the vertical position, until it audibly engages (see Figure 17, page 29).

CAUTION!

Danger of crushing when folding the ramp to the vertical position.



When lifting the ramp to the vertical position, there is a risk of hands or fingers being crushed between the ramp and the frame (rear bumper).

Therefore:

- Do not reach into the gap between the ramp and the frame.



Figure 17: Folding the Ramp Up

⇒ Close the rear doors / tailgate

5.5 Disembarking a Passenger / Unloading a Wheelchair

- ⇒ Deploy the ramp (see Section 5.2, page 22).
- ⇒ Swivel the FutureSafe head and back support (optional) out of the vehicle.
- ⇒ Release the lap belt and the automatic diagonal shoulder belt with which the passenger is secured (optional).
- ⇒ Slacken the retractor belt reels (see Figure 16, page 28).
- ⇒ Unclip the retractor belts from the fittings (see Figure 5, page 17).
- ⇒ Detach the retractor belts from the wheelchair.
- ⇒ Switch the motor of an electrically driven wheelchair ON.
- ⇒ Release the wheelchair's parking brakes.
- ⇒ Take up a position behind the wheelchair so that you can stop the wheelchair safely if it rolls backwards.



WARNING!

Risk of injury through a wheelchair rolling backwards out of control.

The floor section and the ramp form a slope via which the wheelchair can roll down out of control. The passenger in the wheelchair can be severely injured. Material damage can be caused.

Therefore:

- Stand behind the wheelchair to prevent it from rolling backwards.
 - Only then operate the rocker switch such that the indicator lamp in the rocker switch lights up.
-

- ⇒ Operate the rocker switch such that the indicator lamp in the rocker switch lights up (see Figure 7, page 18).
- ⇒ Accompany the passenger out of the vehicle.
- ⇒ Detach the electrically operated belts from the wheelchair.
- ⇒ Allow the electrically operated belts to retract.
- ⇒ Operate the rocker switch such that the indicator lamp in the rocker switch goes out.
- ⇒ Fold the ramp back up to the vertical position, until it audibly engages (see Figure 17, page 29).
- ⇒ Close the rear doors or the tailgate.

5.6 Easy-Flex: Fully Stowing the Ramp

With the access ramp fully folded away and the rear seats in their original position, the vehicle can be used as a standard vehicle (see Figure 18).

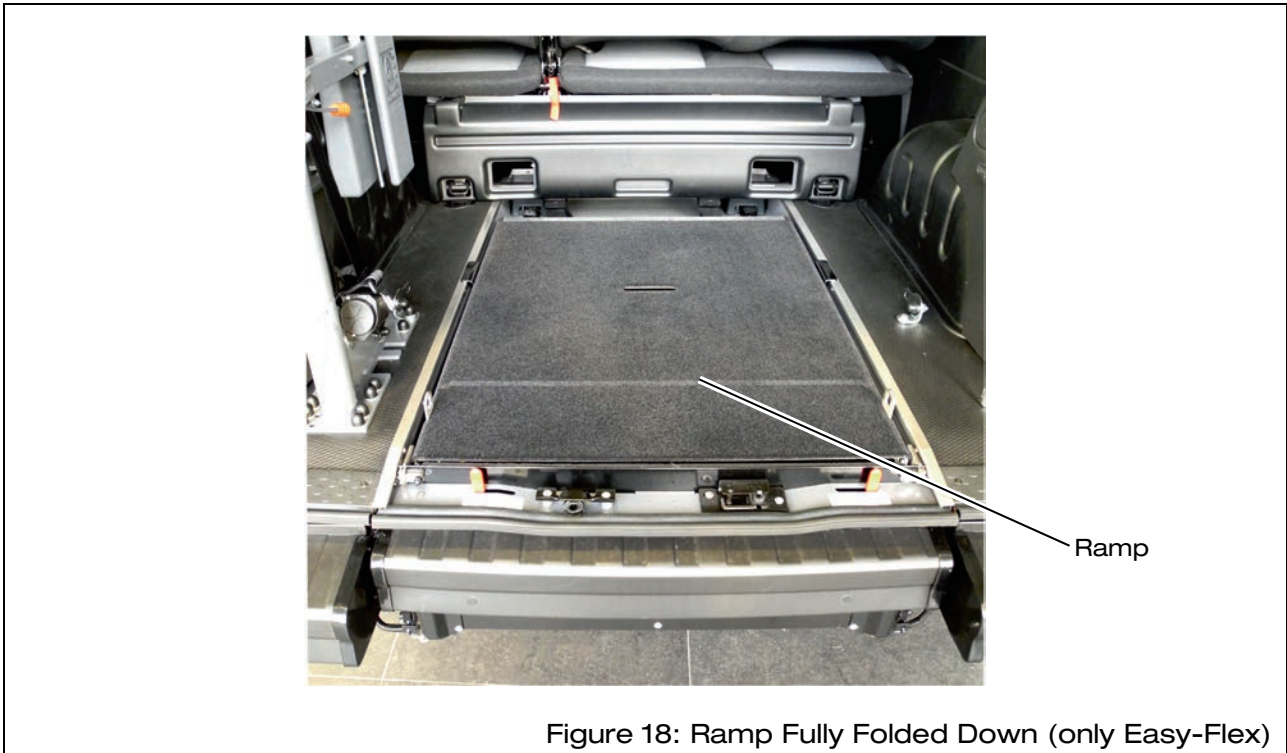

⇒ Push operating lever 1 to the right (see Figure 19).

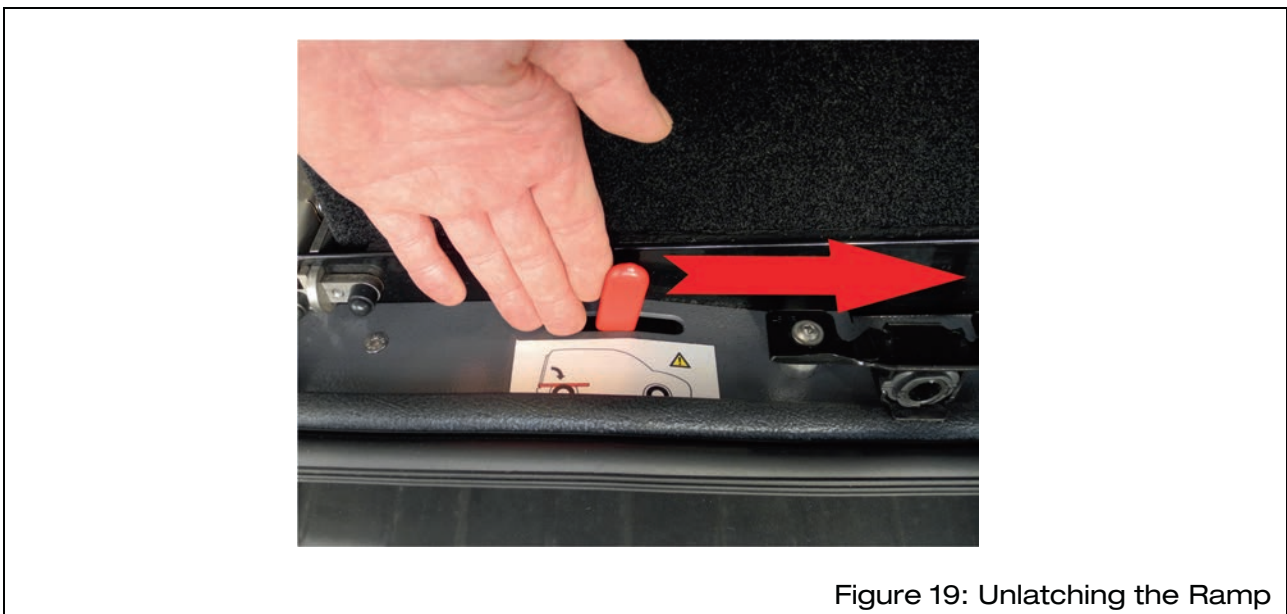



CAUTION!

Risk of injury and danger of material damage when stowing the ramp fully in the vehicle.

When folding the ramp to the horizontal position, there is a risk of being crushed between the access ramp and the floor section. The access ramp can be damaged.

Therefore:

- Keep a firm hold of the ramp until it is fully in contact with the floor section.
- Do not reach into the gap between access ramp and floor section.

⇒ Fold the ramp down slowly, until its bearing surfaces rest on the vehicle's floor at the sides of the floor section (see Figure 20).



Figure 20: Stowing the Ramp

The ramp rests on both sides of the floor section and can be used as a normal luggage compartment floor (see Figure 18, page 31).

ATTENTION!

The ramp can suffer damage if it is overloaded.

Therefore:

- Do not stand on the stowed access ramp.
- Do not place a load of more than 100 kg on the stowed access ramp.



6 Maintenance and Repair

6.1 Safety Regulations for Maintenance and Repair



Read the safety information before carrying out maintenance and repair work (see Chapter 1, page 8).



WARNING!

Risk of injury through missing safety devices.

If safety devices are removed, they will no longer fulfil their function.

Therefore:

- Always refit safety devices if they have been removed (e. g. for maintenance or repair purposes).
-



WARNING!

Risk of injury and material damage if maintenance and repair work is not carried out correctly.

Therefore:

- Only allow specialist personnel to carry out maintenance and repair work.
 - If repair work has been carried out on load bearing parts, this must be inspected by a technical expert.
-



WARNING!

Personal injury and material damage can be caused by using inferior quality spare parts.

The manufacturer will accept no liability whatsoever for damage or injury caused by the use of non-original spare parts or spare parts that have not been approved of by the manufacturer.

Therefore:

- Use only original spare parts or spare parts that have been approved of by the manufacturer.
-

6.2 Routine Maintenance Work

Maintenance tasks to be carried out on a regular basis are listed in the following maintenance schedule.

Contact the customer service department for maintenance work that must only be carried out by a specialist (see Chapter 10, page 51).

6.2.1 Maintenance schedule

| Interval | Work to be Carried Out | Refer to |
|-------------|---|-------------|
| Daily | Functionally test the electrically operated belts. | Section 6.3 |
| | Carry out a visual inspection for damage and deficiencies. Initiate repair work if necessary. | |
| Yearly | For communal or commercial use: Have the access ramp inspected by a technical expert. | Section 6.4 |
| As required | Clean the access ramp. | |

6.2.2 Maintenance records

Enter maintenance and repair work that has been carried out into the maintenance record provided for this purpose (see Section 6.5, page 36). This helps in keeping track of routine maintenance activities.

For records of maintenance work over and above this, it is recommended that you keep your own lists.

6.3 Functionally Testing the Electrically Operated Belts

- ⇒ Fold the access ramp up to the vertical position, until the spring-loaded locking bolts audibly engage.
- ⇒ Operate the rocker switch several times (see Figure 7, page 18). Observe whether the indicator lamp in the red rocker switch lights up when doing so.
- ⇒ Fold the access ramp out until it rests on the ground.

CAUTION!

Risk of injury and danger of material damage when deploying the ramp.



There is a risk of injuries to the legs and feet if the ramp is allowed to fall to the ground out of control. The ramp can be damaged.

Therefore:

- Keep hold of the ramp until it is fully in contact with the ground.
- Allow the ramp to deploy slowly.

-
- ⇒ Operate the rocker switch such that the indicator lamp in the rocker switch goes out.
 - ⇒ Try to pull the electrically operated belts out.
 - ⇒ Operate the rocker switch again such that the indicator lamp lights up.
 - ⇒ Try again to pull the electrically operated belts out.

The indicator lamp in the rocker switch must only light up when the ramp is deployed. The electrically operated belts must only be able to be pulled out when the access ramp is deployed and the indicator lamp in the rocker switch is lit.

If this is not the case:

- ⇒ Do not use the access ramp and have the access ramp's electrical system checked.

6.4 Yearly Inspection

The yearly inspection by a technical expert is basically a visual inspection and functional test. It extends to:

- the condition of all components and devices,
- an inspection for modifications that have been made to the access ramp,
- the completeness and effectiveness of protective and safety devices and
- the completeness of the inspection log.



For detailed information regarding the yearly inspection by a technical expert: see Chapter 8, "Inspection Log Book", page 39.

6.5 Maintenance and Repair Record

| Maintenance Work Carried Out | | |
|-------------------------------------|-----------|---------------------|
| Date | Signature | Remarks / Work Done |
| | | |
| | | |
| | | |
| | | |
| | | |
| | | |
| | | |
| | | |
| | | |
| | | |
| | | |
| | | |
| | | |
| | | |
| | | |
| | | |
| | | |
| | | |

7 Faults and Troubleshooting



WARNING!

Risk of severe injury and material damage if repair work is carried out incorrectly.

Therefore:

- Only allow specialist personnel to carry out repair work.

If faults occur when operating the access ramp, proceed as described in the following troubleshooting table. Contact the customer service department if faults are encountered which cannot be remedied using the information and measures given in the table.

7.1 Troubleshooting Table

| Fault | Possible Cause | Remedial measures |
|--|---|---|
| The ramp does not deploy or stow correctly. | Foreign objects blocking the latching mechanisms. | Inspect the latching mechanisms and remove foreign objects, clean the latching mechanisms if necessary. |
| | A spring-loaded latch is defective. | Check the spring-loaded latches and replace if necessary. |
| | One or more of the gas-operated springs is/are defective. | Check the gas-operated springs and replace them if necessary. |
| | The access ramp mechanism is misaligned. | Have the access ramp mechanism re-aligned. |
| The access ramp rattles when driving. | Adjust the access ramp's play. | See Section 7.2, page 38. |
| The electrically operated belts can not be pulled out. | The rocker switch is defective. | Have a new rocker switch fitted. |
| | The fuse has blown. | Replace the fuse in the vicinity of the battery. |
| | The electrically operated belts are defective. | Have the electrically operated belts replaced. |

7.2 Adjusting the Access Ramp's Play

The access ramp can show signs of play when in the vertical position. This causes the access ramp to rattle when driving.

Figure 21 shows the adjusting screws with which the access ramp's play can be adjusted. Adjuster screws are available both sides of the access ramp.

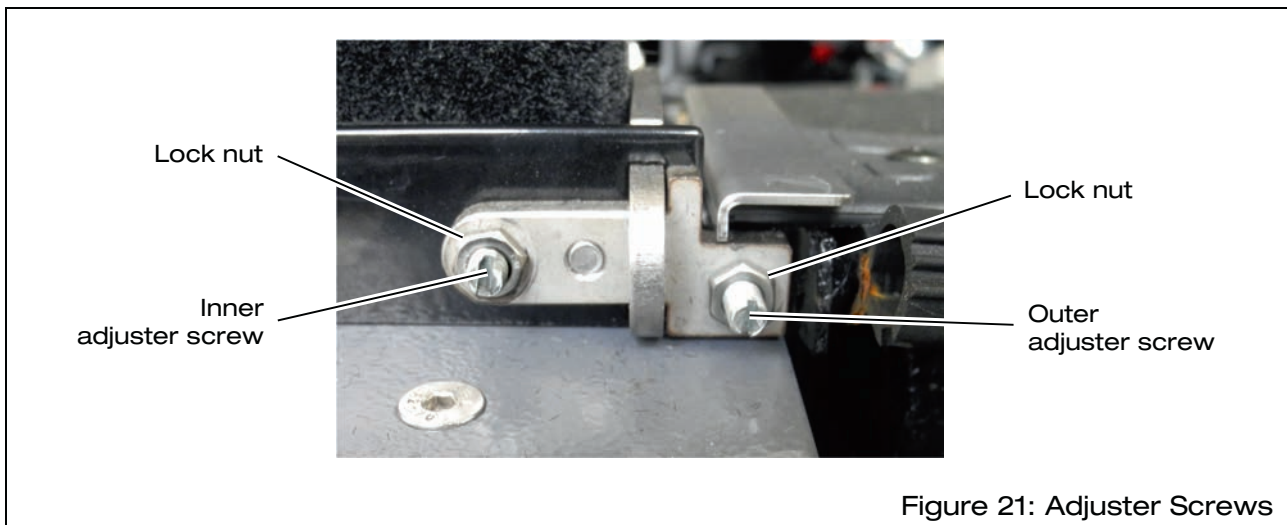

Figure 21: Adjuster Screws

The inner screws (on the left in Figure 21) are used to adjust the play of the ramp that can be folded down inside the vehicle. The inner screws are only available on an Easy-Flex-Ramp.

If the locking bolt is difficult to close, there is too little play. If the access ramp is loose when in the vertical position or rattles when driving, there is too much play.

To adjust the access ramp's play:

- ⇒ Remove the black protective caps from the adjuster screws.
- ⇒ Loosen the locking nuts (see Figure 21).
- ⇒ Turn the adjuster screw in to reduce the amount of play.

Or:

- ⇒ Turn the adjuster screw out to increase the amount of play.
- ⇒ Tighten the locking nut once again.
- ⇒ Check the access ramp's play once again.
- ⇒ Repeat the procedure as often as necessary.
- ⇒ Replace the black protective caps.

8 Inspection Log

Before using the access ramp for the first time, it must be inspected by a technical expert.

If the access ramp is used commercially or as a public utility, this inspection must be repeated at intervals of not more than one year

During inspection, faults affecting the safety should be systematically identified and remedial action taken.

The items to be inspected are listed in the inspection list (see Section 8.2, page 41).



A technical expert is someone who, by virtue of their technical training and experience, has sufficient knowledge in the field of access ramps for vehicles equipped for disabled persons and is sufficiently familiar with the relevant national occupational health and safety regulations, accident prevention regulations and recognised rules of sound engineering practice (e.g. BG rules, DIN standards, VDE provisions, technical rules and regulations of other member states of the European Union or Turkey or other signatory states of the Agreement of the European Economic Area) that they are able to assess the safe working condition of such access ramps for disabled vehicles.



8.1 Inspection Log Master Data Sheet

Master Data Sheet for Easy-Ramp and Easy-Flex-Ramp

Serial No. /Type*

Number plate

Owner

.....

.....

.....

Year built

Commissioned on

* see rating plate

8.2 Inspection List

For a routine, yearly inspection by a technical expert (see information on page 39).

| Mechanical parts | |
|-------------------------|--|
| Fixtures on the vehicle | All securing points in / on the vehicle are in a perfect, tight condition |
| Pivoting elements | All bolts and screwed connections are in a perfect, tight condition |
| General | Functional test and visual inspection of the condition of the entire access ramp |

| Electrical system | |
|-----------------------------|------------------|
| Rocker Switch | Functional check |
| Electrically operated belts | Functional check |



8.3 Inspection Results

Results of the inspection prior to commissioning.

To be observed if installed by a third-party company

Installation inspection for

Serial No. /Type*

Number plate

Installation has been carried out correctly!

Place, date

.....
Installation company / Company stamp

.....
Signature (technical expert)

* see rating plate



Inspection result of a yearly inspection / a re-inspection

Serial No. /Type*

Number plate

Sheet No.

On the access ramp was subject to a yearly inspection in accordance with the inspection list / a re-inspection.

No / the following defects were found:

.....
.....
.....
.....

There are no issues to preclude continued operation.

Place, date

.....
Company / Company stamp

.....
Signature (technical expert)

All defects have been remedied.

Confirmation by the owner or his representative with date and signature

.....
Place / date

.....
Signature (owner)

* see rating plate



Inspection Log

Inspection result of a yearly inspection / a re-inspection

Serial No. /Type*

Number plate

Sheet No.

On the access ramp was subject to a yearly inspection in accordance with the inspection list / a re-inspection.

No / the following defects were found:

.....
.....
.....
.....

There are no issues to preclude continued operation.

Place, date

.....
Company / Company stamp

.....
Signature (technical expert)

All defects have been remedied.

Confirmation by the owner or his representative with date and signature

.....
Place / date

.....
Signature (owner)

* see rating plate



Inspection result of a yearly inspection / a re-inspection

Serial No. /Type*

Number plate

Sheet No.

On the access ramp was subject to a yearly inspection in accordance with the inspection list / a re-inspection.

No / the following defects were found:

.....
.....
.....
.....

There are no issues to preclude continued operation.

Place, date

.....
Company / Company stamp

.....
Signature (technical expert)

All defects have been remedied.

Confirmation by the owner or his representative with date and signature

.....
Place / date

.....
Signature (owner)

* see rating plate



Inspection Log

Inspection result of a yearly inspection / a re-inspection

Serial No. /Type*

Number plate

Sheet No.

On the access ramp was subject to a yearly inspection in accordance with the inspection list / a re-inspection.

No / the following defects were found:

.....
.....
.....
.....

There are no issues to preclude continued operation.

Place, date

.....
Company / Company stamp

.....
Signature (technical expert)

All defects have been remedied.

Confirmation by the owner or his representative with date and signature

.....
Place / date

.....
Signature (owner)

* see rating plate



Inspection result of a yearly inspection / a re-inspection

Serial No. /Type*

Number plate

Sheet No.

On the access ramp was subject to a yearly inspection in accordance with the inspection list / a re-inspection.

No / the following defects were found:

.....
.....
.....
.....

There are no issues to preclude continued operation.

Place, date

.....
Company / Company stamp

.....
Signature (technical expert)

All defects have been remedied.

Confirmation by the owner or his representative with date and signature

.....
Place / date

.....
Signature (owner)

* see rating plate



Inspection Log

Inspection result of a yearly inspection / a re-inspection

Serial No. /Type*

Number plate

Sheet No.

On the access ramp was subject to a yearly inspection in accordance with the inspection list / a re-inspection.

No / the following defects were found:

.....
.....
.....
.....

There are no issues to preclude continued operation.

Place, date

.....
Company / Company stamp

.....
Signature (technical expert)

All defects have been remedied.

Confirmation by the owner or his representative with date and signature

.....
Place / date

.....
Signature (owner)

* see rating plate



Inspection result of a yearly inspection / a re-inspection

Serial No. /Type*

Number plate

Sheet No.

On the access ramp was subject to a yearly inspection in accordance with the inspection list / a re-inspection.

No / the following defects were found:

.....
.....
.....
.....

There are no issues to preclude continued operation.

Place, date

.....
Company / Company stamp

.....
Signature (technical expert)

All defects have been remedied.

Confirmation by the owner or his representative with date and signature

.....
Place / date

.....
Signature (owner)

* see rating plate

9 Electrical Circuit Diagram

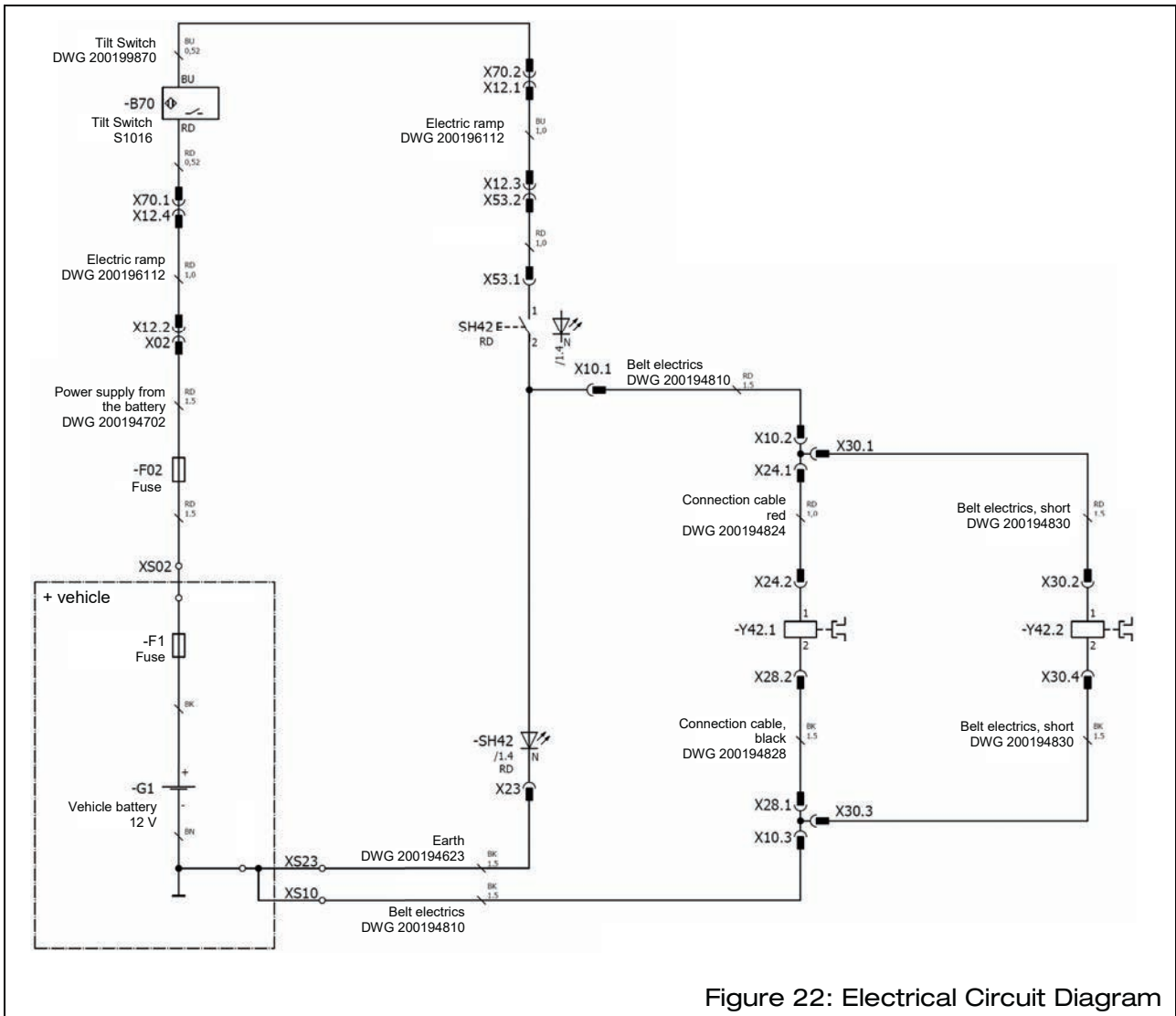

Figure 22: Electrical Circuit Diagram

| Colour | Abbreviation (acc. to IEC 60757) |
|--------|-------------------------------------|
| Black | BK |
| Brown | BN |
| Red | RD |
| Blue | BU |

| Colour | Abbreviation (acc. to IEC 60757) |
|--------|-------------------------------------|
| Yellow | YE |
| Green | GN |
| Grey | GY |

10 Customer Service

The AMF-Brunns customer service department will be more than pleased to assist in ordering spare parts, maintenance and repair work and help with general problems or queries.

The address is:

AMF-Brunns GmbH & Co. KG
Hauptstraße 101
D – 26689 Apen

Tel.: +49 (0) 44 89 / 72 72-30

Fax: +49 (0) 44 89 / 62 45

service.hubmatik@amf-bruns.de

www.amf-bruns.de



NOTE

Guarantee work on the access ramp must only be carried out with the prior agreement of AMF-Brunns GmbH & Co. KG.

The costs of such work will not be accepted by AMF-Brunns without prior agreement.



AMF-Bruns GmbH & Co. KG | Hauptstraße 101 | 26689 Apen
Telephone +49 (0) 4489 / 72 72 30 | Fax +49 (0) 4489 / 62 45
service.hubmatik@amf-bruns.de

www.amf-bruns.de



Reg.-No. Q1 0105027